

Many missions. **One solution.**

www.umsskeldar.aero



UMS Skeldar

Company presentation

Ola Härkegård

2021-11-16



UMS SKELDAR

ABOUT US

UMS SKELDAR at a glance

 **53 %** held by **UMS Aero Group AG**

 **47 %** held by **Saab AB**

Switzerland, Möhlin
Skeldar V-150
- 40 employees

Germany, Benningen
Hirth Engines
- 30 employees

Sweden, Linköping
Skeldar V-200
- 90 employees

**UMS
SKELDAR**





Skeldar V-200



Payload: 20+ kg
Flight time: 5+ h
Range: 100+ km
No runway









Control system architecture

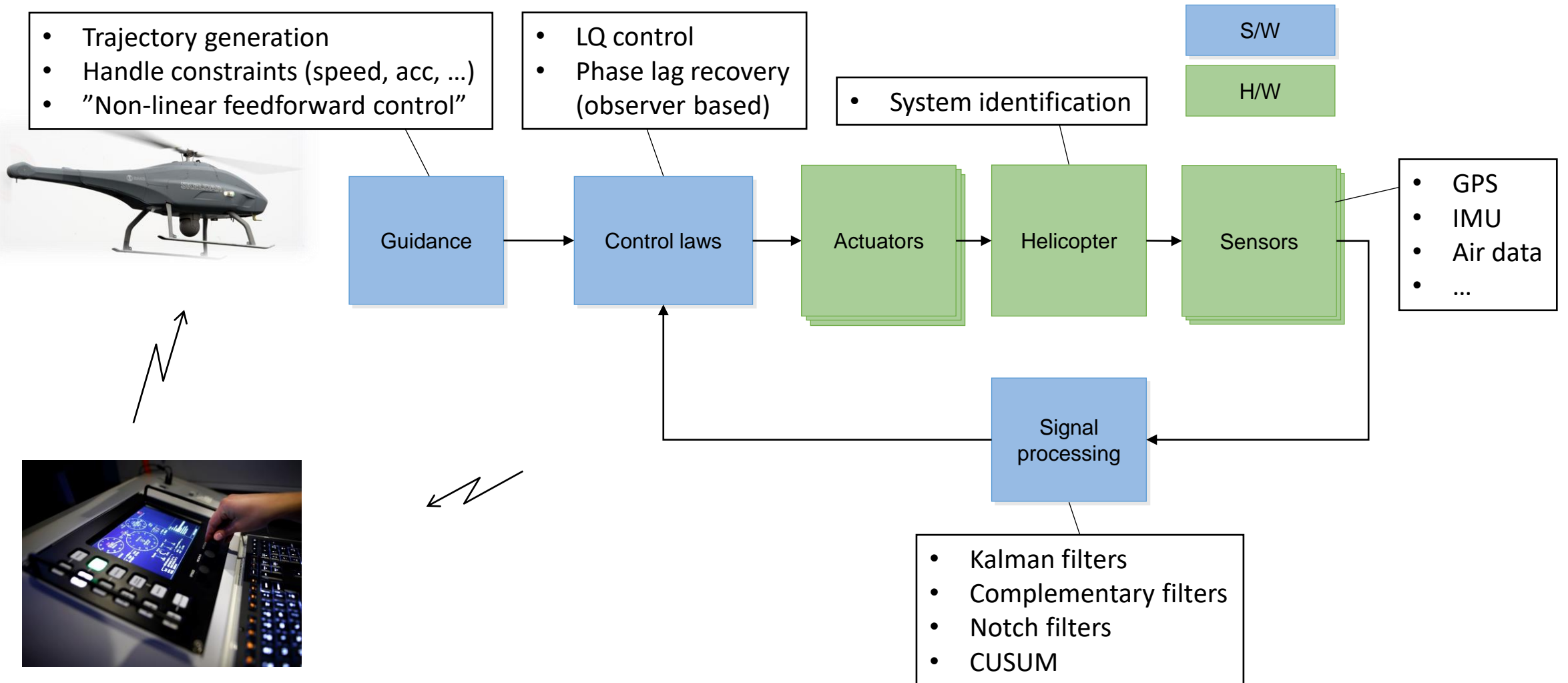

Challenges

Robustness

- GPS outages
- Control laws for the unexpected
- Ship landing in harsh conditions



