



OSKAR LEUFVEN, SCANIA BATTERY PACK AND VEHICLE TESTING

LIFE AS LINK-SIC PHD STUDENT AND BEYOND

14 November 2023

SCANIA

My background

- "Modeling for control of centrifugal compressors"
- Modeling for control vs. Modeling and control
- Test details vs. number of tests
- University vs. industry
- +1year preparation

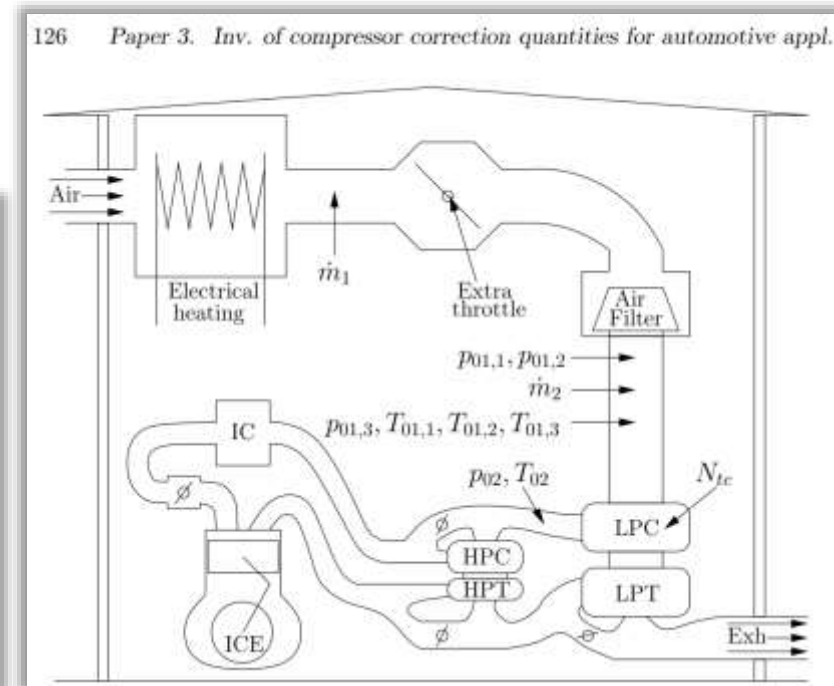
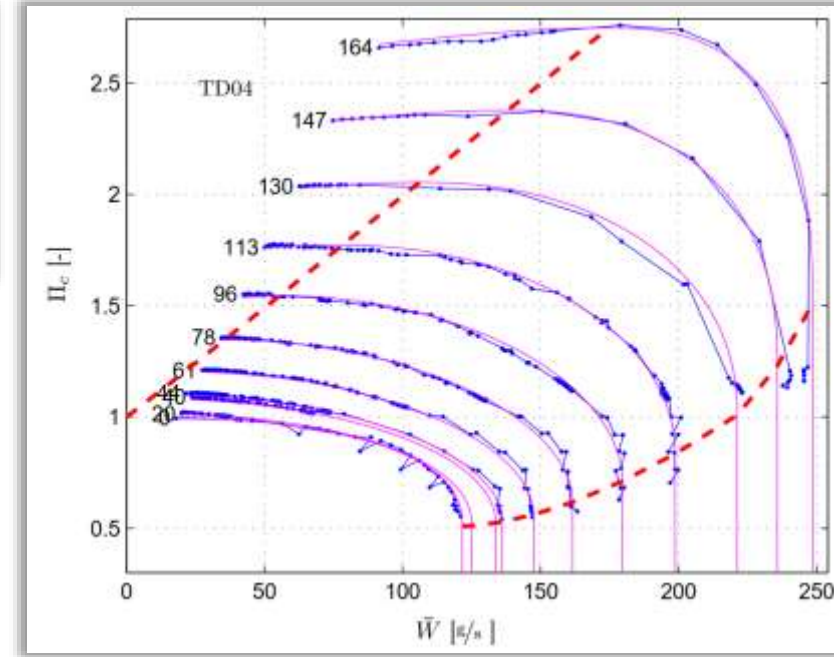



Scania prototyping examples

- Scania Super prototype
 - 6 port sector divided axial turbine stage
 - Piping <1month
- CTT K98 (more next slide..) vs. Dia >140mm



Figure 65: "Six-sector" axial turbine stage. From Paper 7.



Figure 66: Prototype turbine stage, near upper left, lower and axial paper right, turbine housing (lower left) and lower housing (lower right). From Paper 8.



© PhD student and beyond



(My)LinkSIC research in action!

- Joining industrialized research and patents
- Sales org. vs R&D
- The power of language

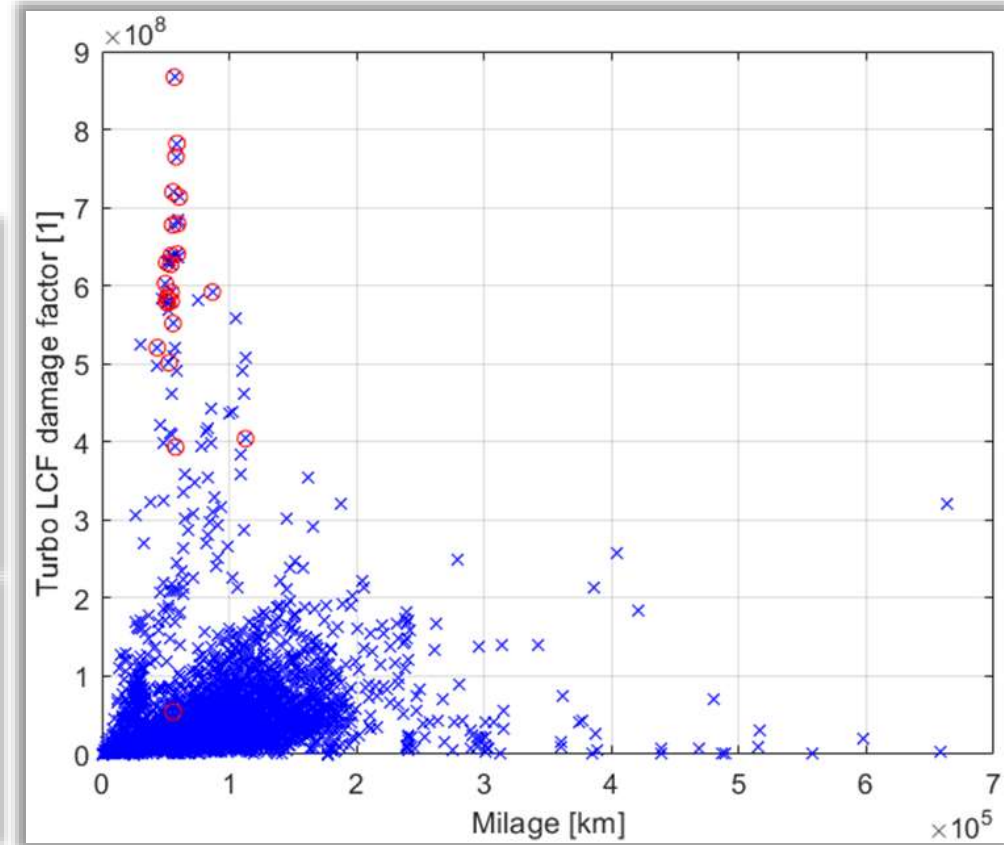
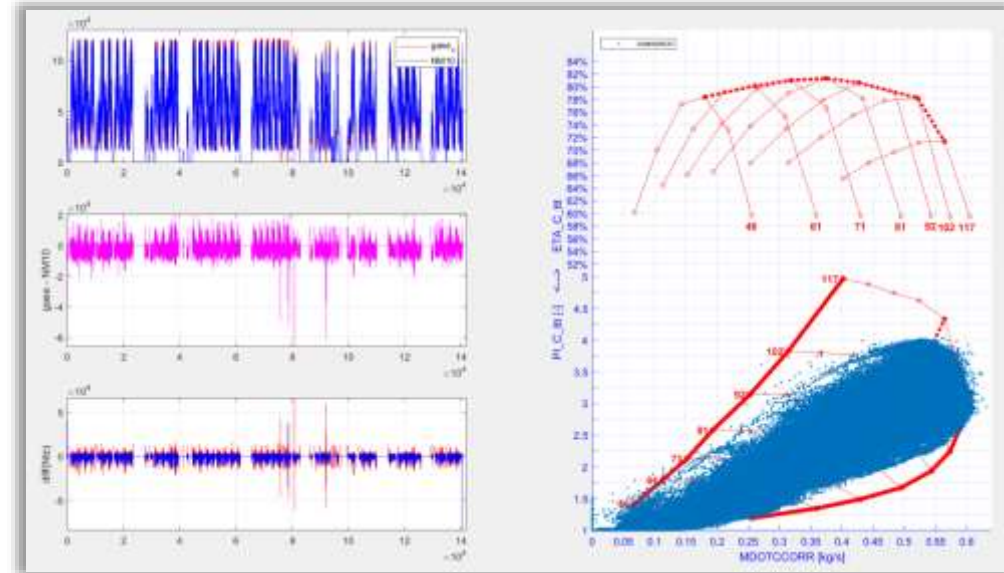



Touching on the electrification journey

- Auxiliary brake legal or customer requirements
 - ICE: CRB, exhaust brake or oil retarder system
 - BEV?
 - Charge battery!
 - But when full?

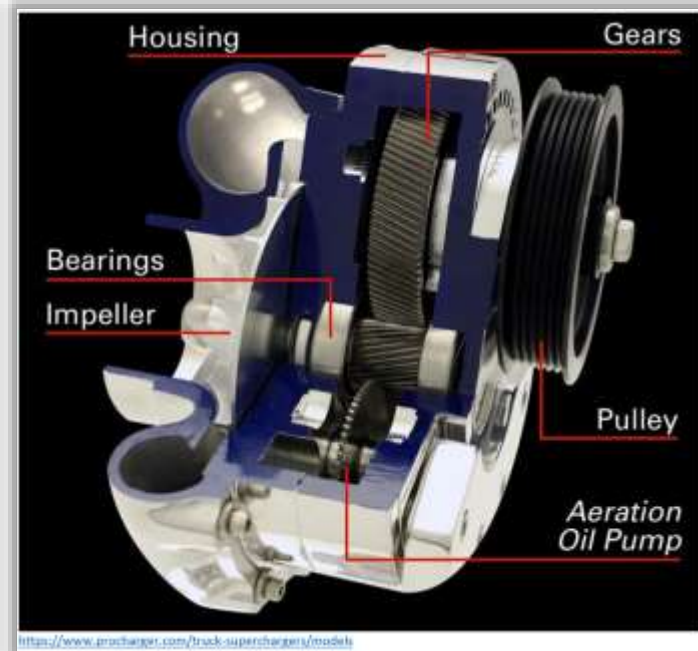



Electrification and digitalization journey

- Will there be a glacier on Helags in the future?
 - "Never let a good crisis go to waste"
- What component will there be most of on a BEV-truck?



Alt Text: A bus parked on the side of a road



https://www.scania.com/group/en/home/newsroom/news/2022/scanias_battery_lab_is_up_and_running.html



Battericellen från Northvolt väger ungefär 2,2 kg och kan lagra 0,8 kWh. 18 celler packas i varje modul och de största batteripaketen Scania bygger innehåller 20 moduler.
Foto: Erik Wedberg / Expressen Lifestyle



Ellastbilen Scania 40 R har 612 hästkrafter och kan komma upp till 35 mil på en laddning. Foto: Erik Wedberg / Expressen Lifestyle

Electrification and digitalization journey

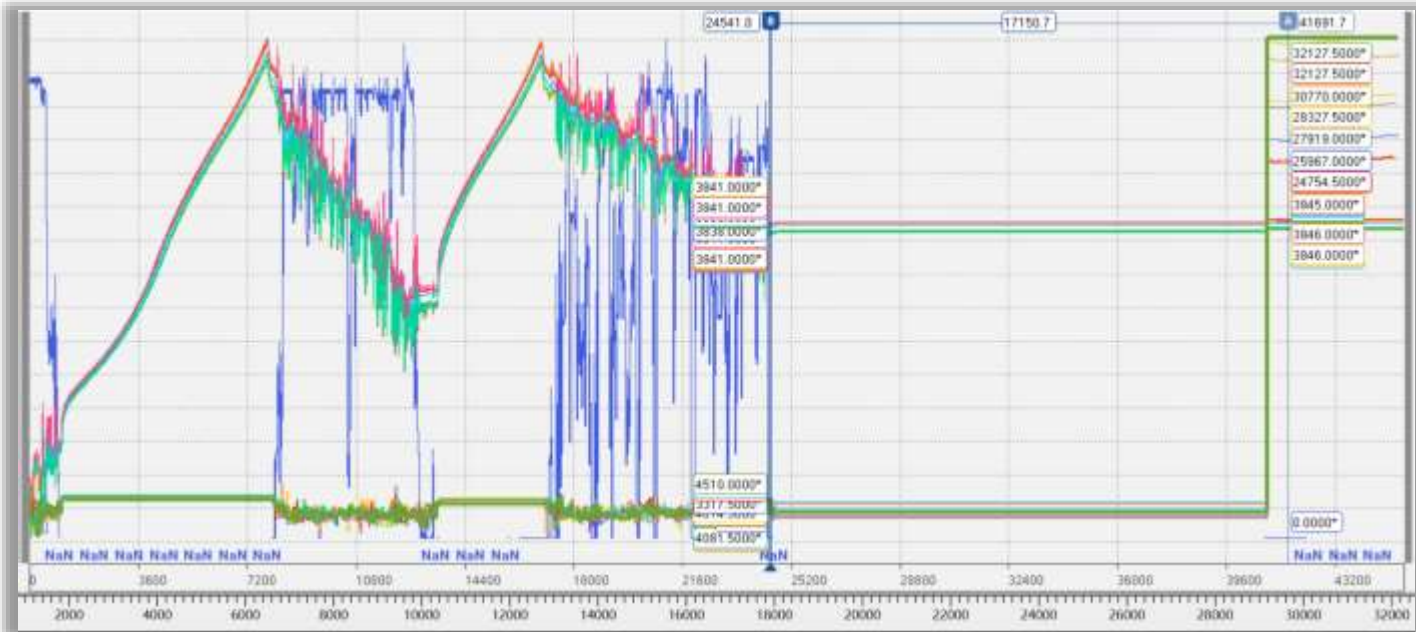

Lastbil gick av vägen: "Föraren är oskadd" – Östersunds-Posten (gp.se)



Lastbil gick av vägen: "Föraren är oskadd"



Scania CV AB / Li



Conclusions and various thoughts

- Do not be afraid to change technology area
 - Trust your developed methods, and yourself!
- It's fun to see one's efforts put into use
 - Research is perishable, make use of it while it is fresh!
- Best results are found when combining strengths

- It is too easy to
 - ...do measurements
 - ...convince higher mgmt of new ways to handle knowledge





OSKAR LEUFVEN, SCANIA BATTERY PACK AND VEHICLE TESTING

QUESTIONS? **SCANIA**